

CTi-11X integrated turbo compressor system

Electrical turbo compressor with integrated electronics and gas bearings for the oil-free supply and recirculation of air and other gases.

- Turbo compressor with aerodynamic optimization and integration of power electronics for highest total efficiency and lowest ratio of volume and weight versus pressure and mass flow
- Aerodynamic variants available for pressure ratios from 1.6 to 1.9 at mass flows ranging from 8 to 18 g/s
- High-speed gas bearings for oil free operation
- Continuous and non-pulsing air supply
- Designed for 48 V, 80 V or 96 V nominal input voltage (unrestricted operation for DC input voltage 40–110 V)

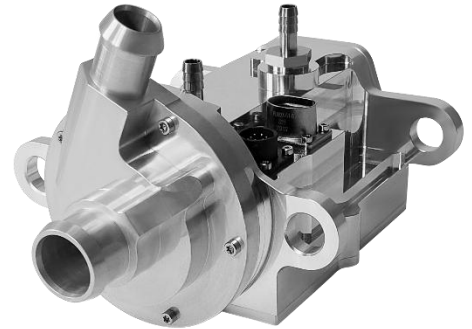

Specifications turbo compressor system

Model CTi-1100

Maximum pressure ratio	1.9 at 13 g/s
Maximum mass flow	17 g/s

Model CTi-1101

Maximum pressure ratio	1.6 at 18 g/s
Maximum mass flow	25 g/s

Model CTi-1102

Maximum pressure ratio	1.8 at 8 g/s
Maximum mass flow	14 g/s

Maximum speed	260,000 rpm
---------------	-------------

Acceleration time ¹	<2.0 s
--------------------------------	--------

Maximum converter DC input power	1.5 kW
----------------------------------	--------

High-voltage input range (unrestricted operation)	40–110 VDC
--	------------

Low-voltage input range	8–32 VDC
-------------------------	----------

Communication interface	CAN 2.0A/B (500 kbps), RS232-USB (service interface)
-------------------------	---

Ambient temperature range	-20–85°C
---------------------------	----------

Protection class	IP67
------------------	------

Mechanical fixation	4x brackets, through hole
---------------------	---------------------------

Dimensions (L x W x H)	242 x 188 x 155 mm
------------------------	--------------------

Weight	3.6 kg
--------	--------

¹ 20 to 80% of maximum speed

All rights reserved. All information in this document is based on Celeroton's best knowledge and is not to be considered as a warranty or quality specification. The information given is designed as a guidance and customers are requested to check the suitability and usability of the product in their specific application with consulting Celeroton. The information herein is subject to change without notification.

Compressor map: CTi-1100

Pressure ratio versus mass flow

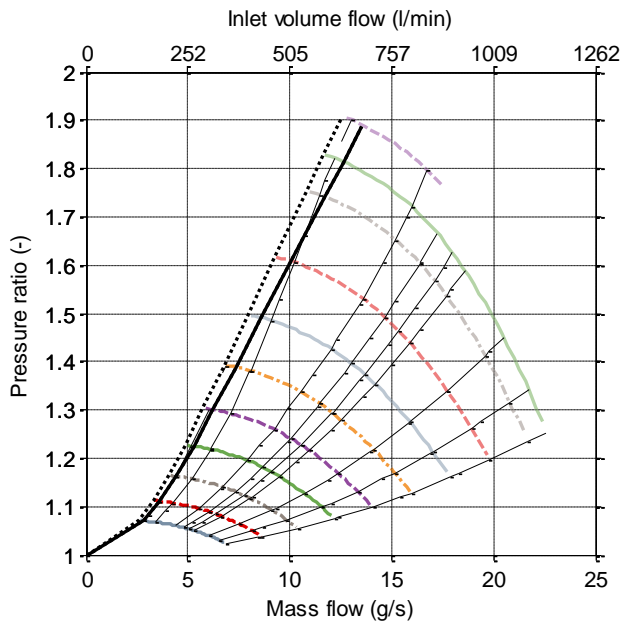

Converter input power versus mass flow

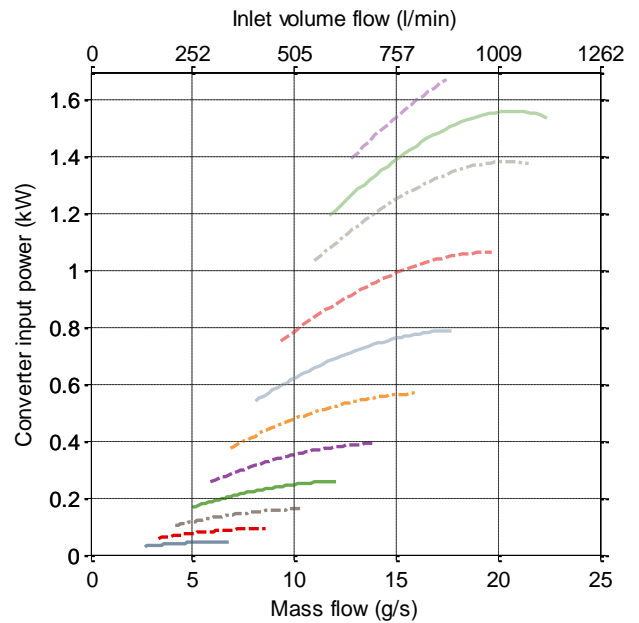

Pressure ratio versus mass flow

Converter input power versus mass flow

Compressor map: CTi-1101

Pressure ratio versus mass flow

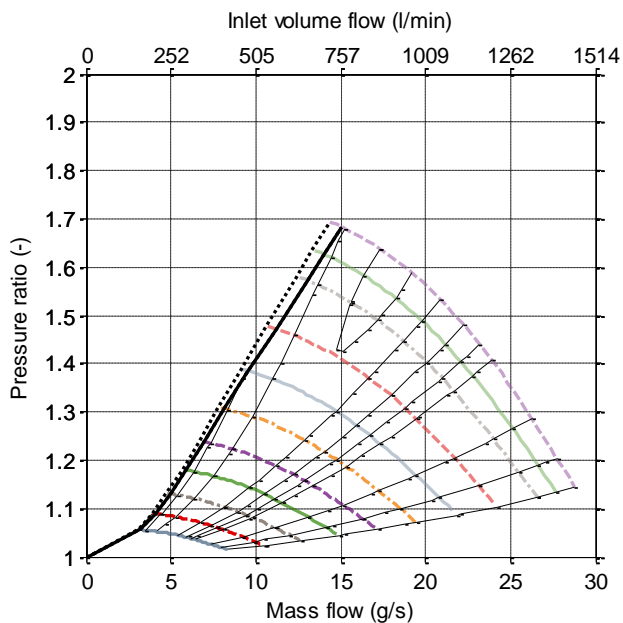

Converter input power versus mass flow

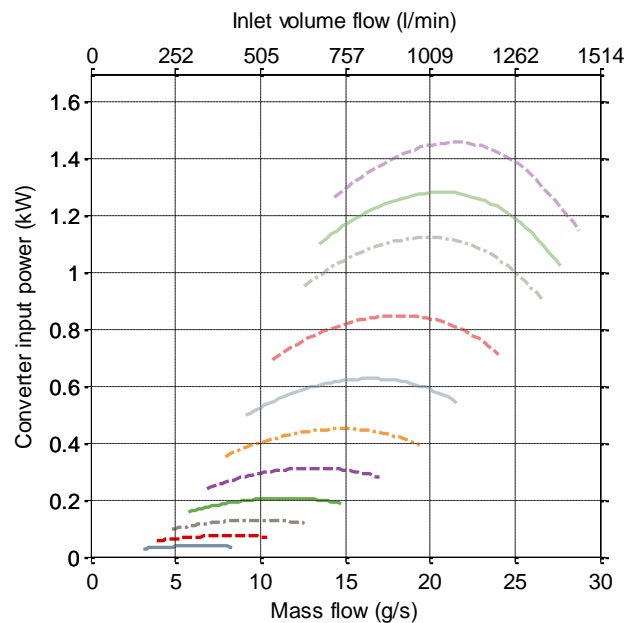

All rights reserved. All information in this document is based on Celeroton's best knowledge and is not to be considered as a warranty or quality specification. The information given is designed as a guidance and customers are requested to check the suitability and usability of the product in their specific application with consulting Celeroton. The information herein is subject to change without notification.

Compressor map: CTi-1102

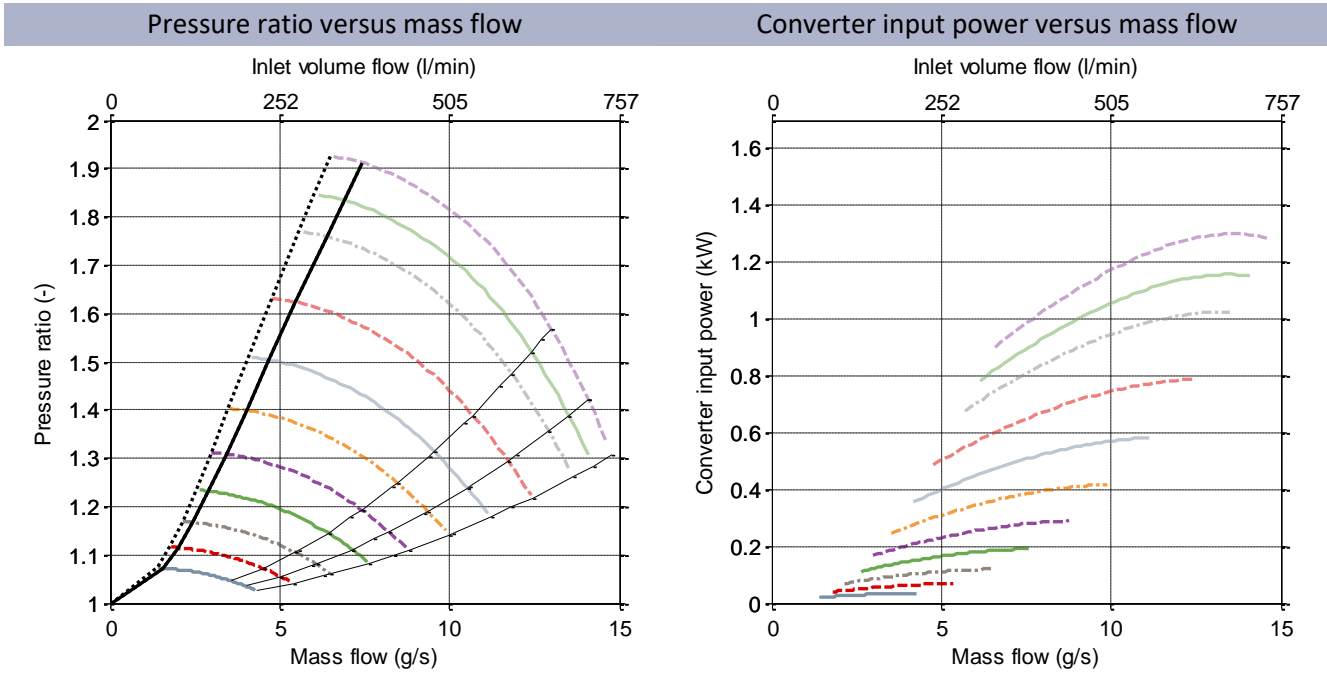

Compressor air interfaces

Inlet air fluid temperature	-20–55°C
Inlet air fluid pressure	0.79–1.05 bara
Interface inlet	Clamp and hose (ID = 34 mm)
Interface outlet	Clamp and hose (ID = 25 mm)

Cooling interfaces

Liquid	Inhibited 50%/50% water glycol mixture
Coolant temperature	-20–75 °C
In-/outlet connector	Clamp and hose (ID = 13 mm)

High-voltage interface

Connector type	Amphenol PowerLok 4.0 (matching cable-side connector: PL182x-60-6)
Cable type	2 x 6 mm ² , shielded
Grounding	1 x M6

Low-voltage interface

Connector type	Amphenol eco mate (matching cable-side connector: RTS6BS12N10S03)
----------------	--

All rights reserved. All information in this document is based on Celeroton’s best knowledge and is not to be considered as a warranty or quality specification. The information given is designed as a guidance and customers are requested to check the suitability and usability of the product in their specific application with consulting Celeroton. The information herein is subject to change without notification.

Drawing in mm [inch]

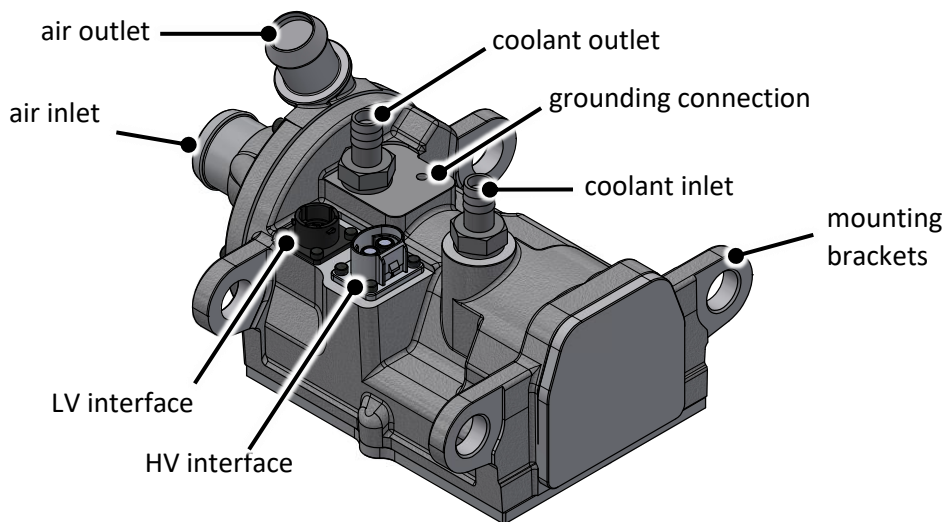
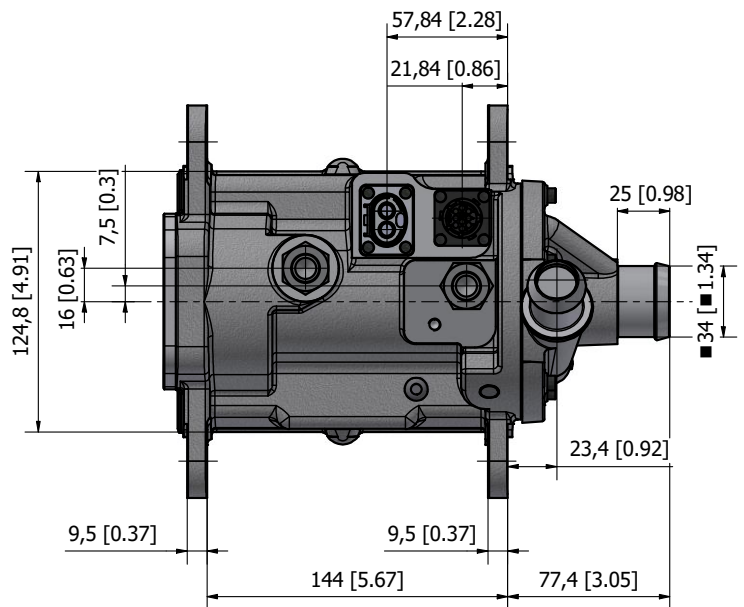
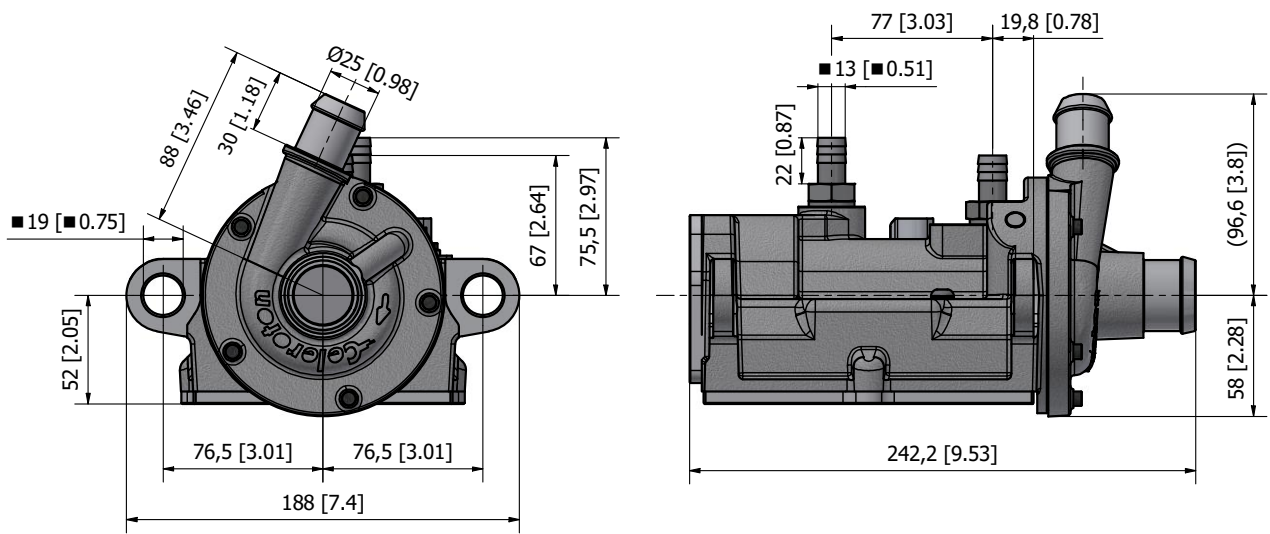

All rights reserved. All information in this document is based on Celeroton's best knowledge and is not to be considered as a warranty or quality specification. The information given is designed as a guidance and customers are requested to check the suitability and usability of the product in their specific application with consulting Celeroton. The information herein is subject to change without notification.



The specifications and compressor maps in this document refer to air (ISO 8778) at the inlet of the compressor: temperature: $T = 20\text{ °C}$, absolute pressure: $p_{in} = 1\text{ bara}$.



Depending on custom specific operation conditions such as e.g. gas inlet pressure and temperature, humidity, cooling conditions, the operation in environmental conditions with vibrations, the compressor maps shown in this document may be different or may have additional limitations. For technical details and further information, please refer to the user manual or contact Celeroton directly.

Order codes

Ordering information	Article number
CTi-1100 - Integrated turbo compressor system	4040077
CTi-1101 - Integrated turbo compressor system	4040078
CTi-1102 - Integrated turbo compressor system	4040081

All rights reserved. All information in this document is based on Celeroton's best knowledge and is not to be considered as a warranty or quality specification. The information given is designed as a guidance and customers are requested to check the suitability and usability of the product in their specific application with consulting Celeroton. The information herein is subject to change without notification.