

© 2009 IEEE

Mechatronics, IEEE/ASME Transactions on Vol. 14 , No. 5, pp. 564-574, 2009

Megaspeed Drive Systems: Pushing Beyond 1 Million r/min

Christof Zwysig	Celeroton Ltd, Switzerland
Johann W. Kolar	ETH Zürich, Switzerland
Simon D. Round	ETH Zürich, Switzerland

This material is posted here with permission of the IEEE. Such permission of the IEEE does not in any way imply IEEE endorsement of any of Celeroton's products or services. Internal or personal use of this material is permitted. However, [no recopying, reprinting, redistributing or reselling is permitted without the written consent from IEEE](#). By choosing to view this document, you agree to all provisions of the copyright laws protecting it.

Mega-Speed Drive Systems: Pushing Beyond 1 Million RPM

C. Zwyssig¹, *Student Member, IEEE*, J.W. Kolar², *Senior Member, IEEE*,
and S.D. Round², *Senior Member, IEEE*

¹Celeroton
Gloriastrasse 35
CH-8092 Zurich, Switzerland

²Power Electronic Systems Laboratory
ETH Zurich
CH-8092 Zurich, Switzerland

Survey paper

Corresponding author

Christof Zwyssig
Celeroton
c/o ETH Zurich
Gloriastrasse 35, ETZ J 65
8092 Zurich
SWITZERLAND
zwyssig@lem.ee.ethz.ch
Phone: +41 44 632 28 37
Fax: +41 44 632 12 12

Abstract

The latest research in mesoscale drive systems is targeting rotational speeds towards one million rpm for a power range of 1 W to 1 kW. Emerging applications for mega-speed drives (*MegaNdrives*) are to be found in future turbo compressor systems for fuel cells and heat pumps, generators/starters for portable nano-scale gas turbines, PCB drilling and machining spindles, and electric power generation from pressurized gas flow. The selection of the machine type and the challenges involved in designing a machine for mega-speed operation such as the winding concepts, a mechanical rotor design capable of 1 000 000 rpm, the selection of magnetic materials for the stator, and the optimization concerning high-frequency losses and torque density are presented. Furthermore, a review of the advantageous inverter topologies, taking into account the extremely low stator inductance and possible high-speed bearing types, such as ball bearings, air bearings, foil bearings and magnetic bearings, are given. Finally, prototypes and experimental results originating from *MegaNdrive* research at ETH Zurich are discussed and extreme temperature operation and Power MEMS are identified as targets for future research.

Keywords

permanent-magnet machines, electric drives, turbomachinery, ultra high speed

INTRODUCTION

Intensive research over the last two decades in the field of variable drives has resulted in a broad spectrum of industrial products with high performance. Therefore, present research is often rather narrow and focused on topics of immediate relevance to industry, such as reducing the number of sensors, improving the mains power quality and integrating the drive within the housing of low power range motors. New research is focused on drive applications for hybrid vehicles and More Electric aircrafts. These applications define new requirements like wide speed ranges and high utilization factors, and raise questions of the reliability and failure modes. A further important use of drives, with specific constraints and research requirements, is in the interconnection of alternative energy sources such as wind energy.

Research at universities is typically undertaken in a close partnership with industry. Hence, new concepts can be realized at a high technology level, with the basic requirement of showing the advantages over the existing products. However, this has the risk that the research targets are adjusted to fit into the existing product development time line. Therefore, the progress is usually limited to incremental steps of already sophisticated drive systems.

In the future, to guarantee highly innovative development of drives technology, it is necessary for universities to take on new challenges. Using this as the background, the Power Electronics Systems Laboratory (PES) at ETH Zurich, in 2004, defined a new main topic of research called *Mega-Speed Drive Systems*

(*MegaNdrives*). The goal is to develop new system concepts of electrical machines, inverters, and controllers to break through the speed barrier of one million rpm. This requires an extension of the performance trajectory of existing electrical drive systems by a factor of 10. A main reason to strive towards the mega-speed range are emerging applications in the areas of non-invasive imaging techniques in medicine [1], dental technology, material processing, air compressors for high-compact fuel cells and gas turbine driven portable power systems (see Fig. 1 and Section II).

MegaNdrives have very high power densities and are typically limited to smaller dimensions and/or power levels in the range of 100 W due to the material strength limitations and thermal limitations (losses in stator iron, windings, bearings and air friction [2]) and/or scaling laws. Interestingly, for the speed target of greater than 1 million rpm, the machine design can be tackled from the view point of macro-systems, i.e. through cylindrical geometries, or by using an extension of microsystems which typically have planar structures to meso scales (so called Power MEMS) [3-5] (cf. Fig. 1). Advantages of employing micro fabrication are, for example, manufacturing with sub micron precision to avoid the limits of relative accuracy that occur with the downscaling of macro systems [6], and the high stiffness of materials with high purity. However, restrictions exist in the limited layer numbers and thicknesses and the magnetic properties of the materials that can be processed. Nevertheless, research at the intersection of macrosystems and power MEMS offers a very high innovation potential through the use of unorthodox combinations of technology.

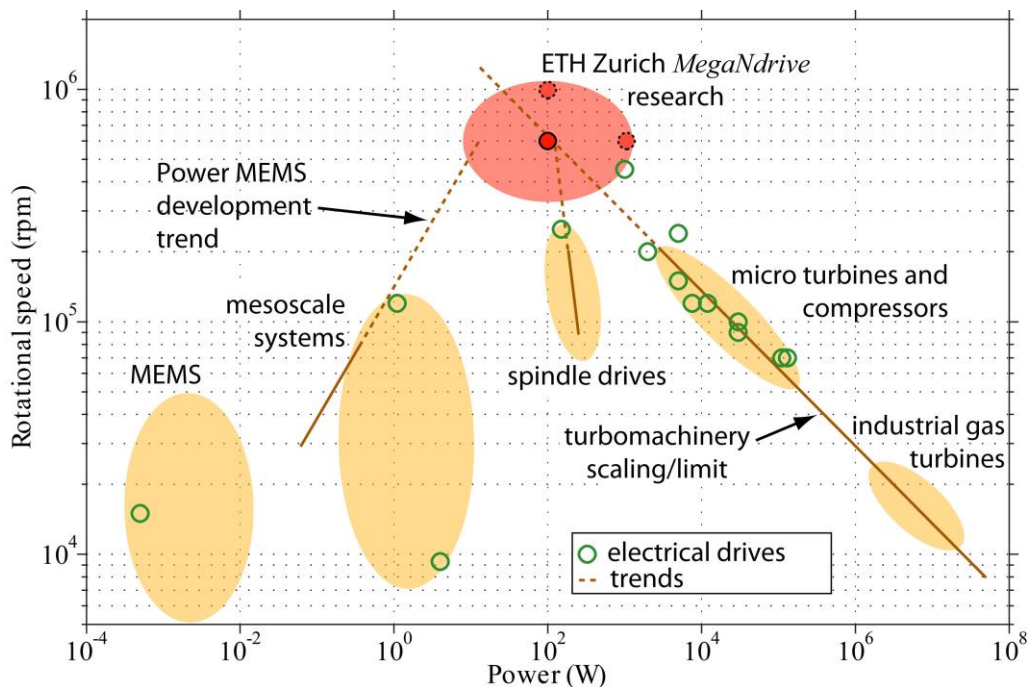

Fig. 1. Emerging application areas and trends for *MegaNdrives* from Power MEMS and turbomachinery.

In contrast to a straight-line innovation path this can lead to fundamentally new concepts that could substantially extend the performance space of variable speed drives.

A further advantage of *MegaNdrives* in connection with possible applications (Section II) is the highly interdisciplinary nature of the research, e.g. there is a strong relationship to the field of mechanical engineering in dealing with rotor dynamics, turbomachinery and thermodynamics. This supports a modern multidiscipline training of postgraduate and Ph.D. students and aids them to prepare for the transfer of the research results into future industrial products.

In this paper, section II presents the emerging application areas with the future requirements for higher speed and increased compactness. Section III gives an overview of the international research landscape within the field of high-speed electrical drives, where only systems in the lower power and/or ultra-high speed ranges are considered. The second part of the contribution (Sections IV-VI) presents the results of ETH Zurich's research into drives with speeds greater than 500 000 rpm, and explains the converter topology selection and system integration. Finally, a short overview is given on the planned future research that includes the consideration of different bearing concepts for the highest speed machines and a significant extension along the temperature performance trajectory that is aiming to use *MegaNdrives* at extreme temperatures up to 550 °C.

I. APPLICATIONS

The small size of electrical machines operating at ultra-high speeds opens up a complete new range of applications. These include drilling micron sized holes, a single handheld drilling tool for dentists, electric-assisted turbochargers for car engines, portable power generation units based on gas turbines and flywheel energy storage systems. Each of these applications and the main emerging application areas of machining and dental spindles, compressors, turbines and flywheels are highlighted in this section, where the present and future speed requirements and output power range are indicated.

A. Machining spindles for grinding, milling and drilling

The recent trend in mechanical systems has been towards smaller sizes, which in turns requires high precision manufacturing. To accomplish this high precision requires the use of smaller and higher speed drilling, milling and grinding tools [7]. For example, notch grinding of silicon wafers requires motor speeds of up to 150 000 rpm [8].

In the electronics industry, the trend has been for reduced sized electronic packages with an ever increasing pin count. For example, fine-pitch BGAs now have over 1700 pins. The PCB has to connect all these pins to the rest of the electrical circuit and this is achieved by using multiple layers (up to 12 layers). The interconnections between the layers are provided by through-hole vias or more recently microvias. Reducing the diameter of the vias allows for more interconnections and facilitates the high pin count components. Presently, both through- and micro-vias with diameters of 75 μm can be produced

economically with mechanical PCB drills (spindles) (Fig. 2) that operate with speeds of up to 250 000 rpm and with a motor power of 200 W [9]. To provide interconnections for larger pin count components requires the use of smaller diameter micro-vias. Presently, the smallest micro-vias have hole diameters of 25 μm , although 10 μm hole sizes being investigated [10]. For these hole diameters only laser drilling is possible, however the main disadvantage with laser drilling is the capital cost, which is over US\$250k. Therefore, it is desirable to use cheaper mechanical drilling, but in order to maintain the same cutting speeds and productivity the rotational drill speed must be increased. For 10 μm hole diameters the drilling speed must be increased to over 1 million rpm [11].

B. Spindles for dental drills and medical surgery tools

Majority of today's dental drill hand pieces are powered by an air turbine from a compressed air supply. Therefore, each hand piece is designed to operate at a single speed and accurate speed control is not possible. A typical dentist would require up to five different speed hand pieces to cover the various tool speed ranges. By replacing the air spindle with an adjustable speed electrical drive could reduce the number of hand pieces, with the added benefit of accurate speed and torque control. The major challenge is to reduce the size of the electrical machine to fit into a normal sized hand piece (Fig. 3).

High speed operation allows for higher performance in terms of cutting speed and the use of smaller diameter drills. In the high-speed range, air turbine hand pieces operate up to 400 000 rpm, with power levels between 10 W and 20 W. The currently available electrical powered hand pieces operate their electric motors up to a maximum of 40 000 rpm, and then a triple-gear system steps the speed up to a maximum of 200 000 rpm (Fig. 3) [13]. To be comparable to the speed range of the air powered hand piece, a direct drive electrical machine requires a speed increase of a factor of 10. The increased speed would also allow a smaller machine design, and therefore providing greater flexibility in the design of an ergonomic hand piece.



Fig. 2. An example of a PCB spindle [12].

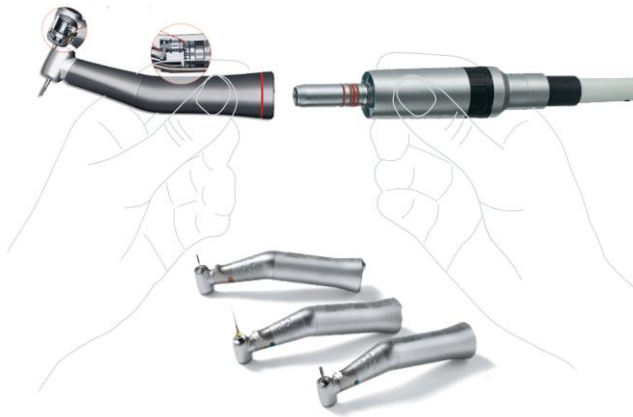

Fig. 3. Electric drive dental hand piece [13].

C. Compressors and Turbochargers

Recent environmental concerns have resulted in increased research activity into the improvement of automotive fuel efficiency. A major thrust has been in the development of hydrogen based fuel cells for propulsion systems. These fuel cells require a constant supply of pressurized air that is provided by an air compressor system. To achieve a compact size, it has been reported that the compressor speed has been increased to 120 000 rpm at a power level of up to 12 kW [14].

To increase the fuel economy and reduce the CO₂ production of the average car, there has been the trend of developing smaller capacity internal combustion engines, both of the gasoline and diesel types. In order to provide a higher performance and improved efficiency a turbocharger is employed. Turbochargers do not perform well at low engine speeds and a turbo lag or a delay in the air boost exists. Electrically assisted turbochargers are under investigation, which provide the pressure boost at low speeds [15]. An electrical machine is mounted on the same shaft between the turbine and the compressor. The electrical machine has to operate at the same rotational speeds of the turbocharger (up to 200 000 rpm) and provide at least 1.5 kW to influence the acceleration performance of the vehicle [16]. The major drawback of the electrically assisted turbocharger is that the electrical machine must operate at extremely high temperatures since there is a direct connection to the exhaust gas turbine. Therefore, there have been developments of a separate air compressor that operates together with the turbocharger to provide additional boost at low engine speeds [17]. Fig. 4 shows a commercial eBooster that has been developed by BorgWarner for the use with their turbochargers. The operating speed is 86 000 rpm with a system input power of 720 W [18]. Increasing the compressor to higher speeds would result in a reduced volume and weight, which is especially important in smaller engine compartments.

D. Portable Power Generation – Gas Turbine Generators

Gas turbine power generation is commonly used in large scale power generation systems up to 100s of MW, where the rotational speed is in the order of 10 000 rpm. There are emerging applications for portable, low power



Fig. 4. eBooster from BorgWarner – an electrically power air compressor providing pressurized air for the support of the turbocharger at low engine speeds [19].

gas turbine based power generation systems. One particular application is for the modern soldier, who now carries electrical equipment with a power consumption of up to 100 W. The existing heavy battery energy storage system, which also needs recharging, could therefore be replaced with a fuel based gas turbine system. At these power levels the gas turbine system occupies a very small volume if the rotational speeds are increased to over 500 000 rpm [20]. Significant challenges exist in manufacturing the gas turbine and the electrical machine. For power levels of less than 10 W the trend is for speeds to over 1 million rpm where the construction uses micro-electrical-mechanical system (MEMS) techniques [3], [21]. As an example, the MIT wafer based gas turbine prototype is shown in Fig. 5.

Additional applications for small portable power supplies are in unmanned surveillance vehicles, autonomous robots and medical applications. Stanford University, in cooperation with M-DOT, has been developing a gas turbine (Fig. 6) with a predicted output power of 200 W and a rotational speed of up to 800 000 rpm. The main application is for powering micro air vehicles [22].

E. Energy Storage (Flywheels)

Flywheels have long been used to store energy. In order to store and extract electrical energy a motor/generator is attached to the flywheel. The modern flywheel systems tend to operate in a vacuum and use magnetic bearings to reduce frictional losses. Two types of flywheel energy storage system exist, those with a large mass and low rotational speeds (<10 000 rpm) and those with low mass and high rotational speeds (>10 000 rpm) [24]. Special applications exist in the aerospace industry for low mass, high speed flywheel systems. In particular, NASA is investigating their use for both attitude control and energy storage in satellites and the international space station. As part of a research project a 3 kW, 40 000 rpm flywheel energy storage system has been tested (Fig. 7) that also provides attitude control. For the next generation of small, near earth orbit satellites the power requirements are reduced as well as the maximum weight. Research into a 100 W, up to 300 000 rpm flywheel motor/generator has been undertaken [25].

F. Other applications

A number of other applications for ultra-high-speed electrical drives exist including those in the field of optical

scanning systems. To facilitate the depth scanning of human retinas through reflectometry measurements from coherent light sources, a transparent cube needs to be rotated at very high speeds [1]. In this reported work an air spindle operating at 580 000 rpm was used. Therefore, good opportunities exist to replace the air spindle with an electrical drive system with speed control.

Another application of high-speed electric machines is in the field of mega-gravity science. This is the study of solids and liquids under high acceleration (and temperatures). An ultracentrifuge has been reported that produces an acceleration of 1 million times gravity through the use of a 220 000 rpm air turbine [27]. It describes that electrical drive centrifuges exist with maximum speeds up to 120 000 rpm, although there is no reason why this can not be increased with the correct design.

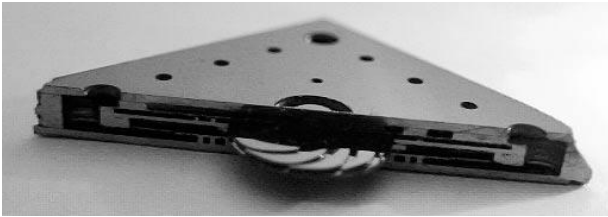

Fig. 5. MIT MEMS gas turbine [3].



Fig. 6. Stanford/M-DOT gas turbine [23].

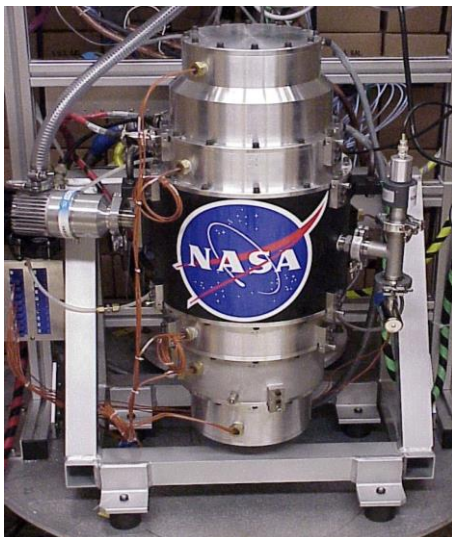

Fig. 7. NASA G2 flywheel for attitude control and energy storage (night-day). 40 000 rpm, 3 kW motor/generator [26].

II. RESEARCH LANDSCAPE

A number of research groups are investigating the different application areas for high speed electrical machines and drive systems. The most challenging aspects for the research occur when the operating speed is above 100 000 rpm.

In [28], various gas turbine and compressors systems are reported. The design target is for 240 000 rpm at a power level of 5 kW. Currently, the system is operating at 180 000 rpm at no load. A fuel cell air compressor operating at 120 000 rpm and 12 kW has been reported [29]. In [30], a 1 kW generator operating at 452 000 rpm has been reported as the world's fastest PM brushless DC motor/generator in production. At the lower power level, MIT is developing portable power gas turbines on a micro scale [3]. The target speed for their electric generator speed is 1.2 million rpm, while they have presently achieved 15 000 rpm. A micro fabricated axial-flux permanent magnetic generator has been reported in [4]. The generator has been fabricated using a combination of micro fabrication and precision machining. At a rotational speed of 120 000 rpm, the generator produced 2.5W of electrical power. [31].

For dental hand pieces, [32] reported on a design target of 150 000 rpm at a power level of 10 W. This was constructed and the target achieved. In the application area of machining tools, a design target of 150 000 rpm, 5 kW is reported [7]. The achieved speed is 100 000 rpm at no load and 60 000 rpm under load. Commercially available products from ATE obtain speeds of around 200 000 rpm at power levels between 200 W and 900 W [33]. Application areas for these machines include grinding and PCB drilling.

For electrically assisted turbochargers, the target speed for the electric drive is 120 000 rpm at a power level of 7.5 kW. Currently, no results have been reported in [15].

In the area of energy storage and attitude control flywheels for aerospace applications, the only reported system above 100 000 rpm is that in [25]. The design target is 300 000 rpm at a power level of 100 W, however only 32 000 rpm in a test run has been currently achieved.

In summary, commercial drives are readily available at speeds below 100 000 rpm. Above 100 000 rpm and less than 250 000 rpm special industrial drives are available. The highest reported speed is 452 000 rpm at 1 kW [30] although very little information is available on its application. Above 500 000 rpm there are only a handful of pure research projects being undertaken, although there have not been conclusive results. One thing is for certain, there are emerging applications in the areas of portable power, drilling spindles and compressors and therefore good research opportunities exist in the field of ultra-high-speed electrical drives.

Since 2004 ETH Zurich has been researching ultra-high speed machines with speeds over 500 000 rpm. A 500 000 rpm, 100 W electrical drive has been reported in [34] and [35], and recently a 500 000 rpm, 1 kW and a 1 million rpm, 100 W drive system have been realized. The design, construction and testing of these ultra-high-speed electrical drive systems is not trivial. There are many

challenges to overcome and new solutions to be developed.

The main challenges are; firstly, in the machine design where the reduction of the high-frequency electrical losses and the selection of a high-speed mechanical rotor construction are essential. Secondly, selection of a suitable compact, power electronics topology (application dependent) for driving ultra-high-speed machines is needed. Thirdly, a sensorless rotor position detection method that can operate at the maximum speed has to be implemented. Lastly, there are the challenges in the integration of the complete drive system, which include selecting the correct bearing technology, performing a sophisticated thermal design and analyzing the rotor dynamics.

The remainder of the paper will highlight these challenges, the design of the electrical machine, power electronics and controller, and will finally present the realized prototypes of ETH Zurich's *MegaNdrives*.

III. ELECTRICAL MACHINE

A. Machine Scaling

The power S available from an electrical machine can be written as

$$S = Cd_r^2ln \quad (1)$$

where d_r is the rotor diameter, l the active length and n the rotational speed (in Hz or rpm, depending on the definition of C). Esson's utilization factor C is dependent on the machine type, and other various variables such as the cooling system and size of the machine [2], [6]. Using given data for small permanent-magnet machines [6] and (1) the active volume of the machine can be estimated for a given power and speed. The volume of a machine decreases with increasing speed, which leads to very small machines for ultra-high speeds.

Furthermore, for a given speed, the diameter of a rotor is limited by the maximum allowable mechanical stresses. With a maximal length to diameter ratio and (1) this leads to a relationship of speed and maximal available power. Different relationships have been identified, for example in [36] and [2]. Therefore, an ultra-high-speed drive not only implies high-speed operation, but a combination of high speed and high power.

Scaling a machine with a constant power rating and efficiency, and therefore constant losses, to higher speeds leads to increased losses per surface area, since the size of the machine decreases. This leads to lower utilization factors and the need for more sophisticated thermal designs for ultra-high-speed machines.

In summary, for a given speed, there is a power limit depending on the machine design, materials used, rotor dynamics and thermal constraints. With the technology used in the *MegaNdrives* a 500 000 rpm machine is limited to approximately 1 kW of shaft power.

B. Machine Selection

There are two basic concepts of electromechanical energy conversions, machines based either on electric or magnetic fields. At the required power levels of the typical applications and for the expected machine dimensions in

the millimeter range, a magnetic machine is the better choice.

The rated current of a magnetic machine scales proportionally with the machine dimensions [6]. Therefore, the flux density in an electrically excited motor, e.g. induction machines (IM) or switched reluctance machines (SRM), decreases with decreasing size. In contrast, permanent magnet flux density remains constant for decreasing machine volume. Therefore, only permanent magnet machines are considered with the aim for a low system volume [37].

High-speed operation requires a simple and robust rotor geometry and construction. The commutator employed in dc machines produces additional friction and limits the speed (to typically 25 000 rpm). Therefore, the only machine types left that meet both small size and high-speed requirements are the brushless dc (BLDC) machine, fed by square-wave currents, and the identically constructed permanent magnet synchronous machine (PMSM), fed by sinusoidal currents. For these machines both slotless and slotted stators could be employed. In [38] the slotless configuration is found to be the better choice for high-speed operation because of the simpler manufacturing of the stator core and the reduction of eddy current losses in the rotor (no slotting harmonics and less armature current reaction).

The ETH Zurich machine design has a diametrically magnetized cylindrical $\text{Sm}_2\text{Co}_{17}$ permanent magnet encased in a titanium sleeve for sufficiently low mechanical stresses on the magnet. The slotless stator core consists of high-frequency iron laminations, and the three-phase air-gap winding is made of litz wire for low copper losses. The cross-section of the machine is illustrated in Fig. 8.

C. Machine Design and Optimization

For ultra-high-speed operation, the mechanical rotor construction and the minimization of high-frequency losses are the main challenges. The copper losses consist of the current dependent resistive losses in the stator winding, which include the influence of the skin effect, and of the proximity effect losses, which are mainly due to the eddy currents induced by the magnetic field of the permanent magnet. The iron losses in the stator can be estimated with the Steinmetz equation. Air friction losses are an important part of the total losses in an ultra-high-speed machine as they roughly scale proportional to the surface area and by the third power of the surface speed. For simple geometries, such as cylinders and disks, air friction losses can be calculated analytically with friction coefficients based on empirical data.

The mechanical rotor design is based on a shrink-fit of the magnet into a titanium sleeve. The design is such that the stresses in magnet and sleeve are below the tensile strengths of the materials. Furthermore, manufacturing for lowest eccentricity and a rotor dynamic analysis are further design aspects.

Recently, a 100-W, 500 000-rpm permanent-magnet machine has been designed and investigated experimentally [34], [35]. Based on this design, an optimization method for highest efficiency, considering mechanical limitations, has been developed [39]. It is

based on analytical models for the magnetic field, the high-frequency copper, iron and air friction losses, and the mechanical stresses. Compared to a traditional motor design, this optimization procedure leads to a small rotor diameter for low air friction losses, thin litz wire strands for reducing the proximity effect losses and an amorphous iron stator core for low iron losses. In Fig. 9 the optimization result of the inner dimensions of a machine is shown, where a reduction of 37% (from 14.2 W to 9 W) of the initial losses is achieved. The full loss minimization makes it possible to reduce the calculated losses by 63% as compared to a machine design not considering air friction losses, and a machine efficiency of 95% can be achieved despite the ultra-high-speed operation.

IV. POWER ELECTRONICS

In Section III.A it has been shown that scaling a machine to higher speeds leads to a smaller volume, which is advantageous in many applications. In order to obtain a small and lightweight total system, the power electronics interface must also be optimized for a low volume and weight.

In contrast to electrical machines, the size of the power electronics mainly scales with power rating and is minimized by choosing the correct topology through efficiency improvements and the use of high switching frequencies. For systems with high power ratings, the size of the control electronics is negligible compared to the power electronics. However, for ultra-high-speed machines with low power ratings (e.g. 100 W), the control

electronics size becomes significant. Generally, the size of the control electronics scales with the complexity of the control method selected and the complexity depends on the topology and the modulation schemes used.

In order to drive the machine with a PWM inverter, a very high switching frequency (at least 10 times higher than the fundamental frequency of the machine) and a high-bandwidth current control loop are needed. However, the high control dynamics that can be achieved with a PWM inverter are not required for majority of the applications. In [40], the PWM inverter is compared with two different block commutated converter topologies in terms of the number of semiconductor devices, size of passive components, control complexity, and ease of implementation of sensorless control.

In the literature, the selected inverter topology and commutation strategy is referred to as a variable dc link inverter [41], or a pulse amplitude modulation (PAM) inverter [42] or a voltage source inverter (VSI) with block commutation [43]. It consists of a standard voltage source inverter topology and an additional dc-dc converter as shown in Fig. 10, and has a bi-directional power flow capability. The six-switch inverter is controlled with six-step or block commutation, which means that each switch is conducting for 120 electrical degrees and, therefore, switched with the fundamental frequency of the machine. The dc voltage (or the dc current) can be controlled with the duty cycle of the dc-dc converter. Eight switch signals are needed to drive the gates of the transistors: two PWM signals for the dc-dc converter and six signals for the inverter. The dc current, for the torque controller, and the stator voltages, for the sensorless rotor position detection and speed controller, are measured and passed to the control system.

V. CONTROL SYSTEM

The main tasks of the control system (Fig. 10) are the commutation of the inverter switches (dependent on the rotor position), and the cascaded current (torque) and speed control loops. The control system also provides communication with an external interface setting the speed reference, for example a PC. The current reference is set by the speed controller. The rotor position directly sets the switch state of the inverter, whereas the actual speed is passed directly to the speed controller. The starting of the machine is achieved by applying impressed currents and a speed ramp.

In contrary to standard PWM inverters, in this topology the dc link current is controlled. On average, this dc link current is proportional to the phase currents, i.e. the phase currents defining the electrical torque can be controlled with a bandwidth depending on the passives in the dc link and the motor inductance. Since all of the applications for the *MegaNdrive* require low dynamic speed control, simple torque control via the dc link current is sufficient. The advantages of this control method are the low computation effort and only a single, non isolated current measurement needed.

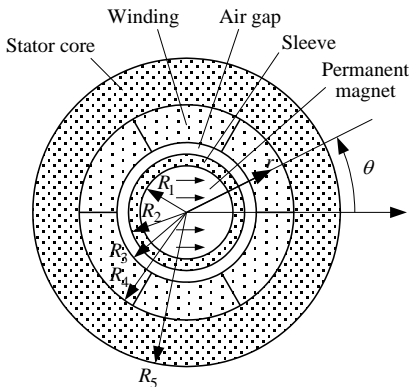

Fig. 8. Machine cross-section: diametrically magnetized cylindrical permanent magnet rotor inside a slotless stator.

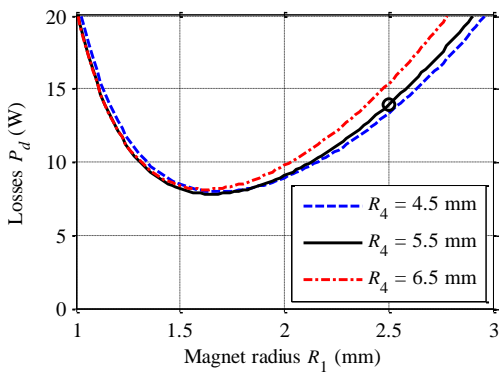

Fig. 9. Losses of a machine with fixed outer dimensions of the stator core ($R_5 = 8$ mm, $L = 15$ mm) and a shaft power of 100 W at a rotational speed of 500 000 rpm for variable magnet radius R_1 . The circle shows the value for the traditional design [34].

A. Sensorless Rotor Position Estimation

A sensorless technique is used to control the stator currents, in order to overcome the disadvantages of rotor position sensors, such as an increased failure probability and an axial extension of the machine. Especially in ultra-high-speed machines, a longer rotor is unwanted because the critical speeds are lowered.

Traditional sensorless control methods use model based estimation of the back EMF to calculate the rotor angle at any instant. The disadvantages of these methods are a large computation effort and the requirement of phase current measurements.

For an inverter with block commutation, the back EMF can be directly measured during the off intervals of the switches in each phase. The detected zero-crossings can then be phase-shifted by 30 electrical degrees and used for the switching decisions, as described in [44] for brushless dc (BLDC) motors. The stator current is usually controlled to be approximately perpendicular to the permanent-magnet flux, thus corresponding to maximum torque-per-current operation. In this scheme, only digital signals are processed, and the computation effort is limited. Nevertheless, unwanted zero-crossings have to be digitally masked out, and the 30-degree phase shift implemented. The limited speed range due to the speed dependence of the back EMF amplitude and noise sensitivity are further drawbacks.

In the *MegaNdrive* sensorless control, the stator flux position is estimated by integrating the terminal voltages, resulting in signals that are in phase with the stator flux. The detected zero-crossings of these signals are then directly used for switching the inverter. That means that the currents are controlled to be perpendicular to the stator flux Ψ_s , as can be seen in the phasor diagram in Fig. 11, instead of the permanent-magnet flux Ψ_{PM} . A comparison to the maximum torque per current operation can be made by considering the steady-state stator current displacement

$$\delta = \arcsin\left(\frac{L_s \hat{i}_s}{\Psi_{PM}}\right). \quad (2)$$

The displacement is depending on the stator inductance L_s , the peak stator current \hat{i}_s and the permanent-magnet

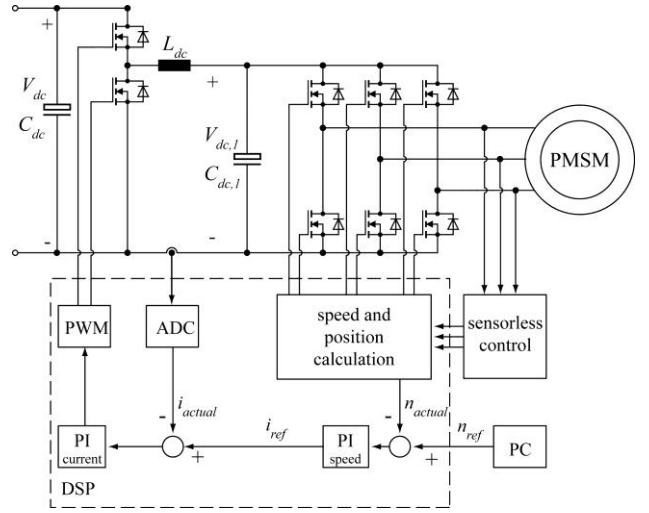

Fig. 10. Power electronics and control system for driving an ultra-high-speed permanent-magnet machine (*MegaNdrive*).

flux Ψ_{PM} . For ultra-high-speed machines, and especially for slotless machines, the ratio of inductance to permanent-magnet flux is usually very small [2], which results in small current displacements of only a few electrical degrees for rated current, and therefore results in only a small torque decrease by using stator flux and not the permanent magnetic flux.

Further advantages of this sensorless technique are that, due to the integrator, the terminal voltages are filtered and noise is reduced, the signals are phase shifted by -90 degrees and the zero-crossing of the signals occur at a commutation instant. The integrated terminal voltages lead to signals with almost constant amplitudes, due to the increase in terminal voltage, but decrease in the gain of the integrator with increasing speed. Similar sensorless techniques have been described in [45] for a BLDC motor and in [11] for a permanent-magnet synchronous motor fed by a PWM inverter or a linear amplifier.

VI. SYSTEM INTEGRATION

The system integration is one of the main challenges in an ultra-high-speed drive system. All the applications are directly driven, which means the machine is directly coupled to the application. Therefore, an integrated design is required, considering mechanical stresses, rotor dynamics, bearing system and thermal design.

As an example, the system integration considerations for the Solar Impulse cabin air pressurization system are described. The Solar Impulse project aims to have an airplane take off and fly autonomously, day and night, propelled uniquely by solar energy, right round the world without fuel or pollution [46]. In the Solar Impulse airplane, the solar energy collected during the day is not only stored in batteries, but also in height. For altitudes up to 12 000 m a cabin air pressurization system is needed. This should be lightweight, compact and efficient in order not to penalize the needs of the propulsion. ETH Zurich is

developing the cabin air pressurization system (Fig. 12) for the Solar Impulse airplane.

A. Bearing Technology

For machine speeds greater than 500 000 rpm the selection of a suitable bearing is a main issue. In this section the possible choices are briefly compared.

High-speed ball bearings are commonly used in the dental industry, and bearings are available for speeds up to 500 000 rpm. The main advantages of ball bearings are the robustness and small size. The main disadvantages are the

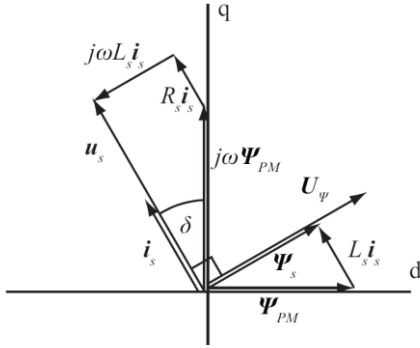

Fig. 11. Phasor diagram for the *MegaNdrive* sensorless control (not drawn to scale).

limited operating temperature and a lifetime dependent on lubrication, load and speed.

Static air bearing, dynamic air bearings and foil bearings levitate the rotor with air pressure, either generated with an external supply (static) or by spinning the rotor (dynamic and foil). They all demonstrate low friction losses and a long lifetime. Foil bearings are reported for speeds up to 700 000 rpm and temperatures up to 650 °C, but are not commercially available and require a complex design procedure.

Magnetic bearings levitate the rotor using magnetic forces and have similar advantages as air bearings [47, 48]. However, active magnetic bearings require sensors, actuators and control, which results in high complexity and increased bearing volume.

Hybrid bearings can incorporate the advantages and eliminate the drawbacks of different bearing types. For example, a combined aerodynamic and magnetic bearing can eliminate the wear of the air bearing at start and stop and provide a control and stabilization possibility, whereas the air bearing can take the main load.

For the Solar Impulse system ball bearings are chosen due to the simplicity, robustness against mechanical impacts, small size and avoidance of auxiliary equipment.

B. Thermal design

The thermal design of an ultra-high-speed drive system strongly depends on the application, since the machines are directly integrated into the application. For example, in a turbocompressor system there is additional cooling of the rotor and casing due to the air passing impeller and inlet. In contrary, in a gas turbine there is a heat source in rotor and housing due to the close proximity to the turbine. A machining spindle running on static air bearings has forced air cooling of the rotor due to static air flow.

Furthermore, for a given power, the scaling of a machine to higher speeds leads to a lower volume due to

the lower torque demand (see Section II), which leads to a smaller cooling surface. Therefore, for increasing speed, an improved cooling concept has to be implemented or the efficiency of a machine has to be increased.

C. Rotor Dynamics

For high-speed operation of rotating machinery, the rotational speed might exceed the lower critical speeds of the rotor system. Lower speed systems are operated below the first critical speed, whereas ultra-high speed machines might run overcritical, which is in between two critical speeds. Then, critical speeds have to be passed as fast as possible while induced oscillations have to be sufficiently damped. The bending modes are speed dependent, although, with the *MegaNdrive* rotors, there is only a small change in the natural frequencies.

For the Solar Impulse system, ball bearings are used. The stiffness of the bearings and the weight of the rotor mainly determine the first two bending modes. These resulting critical speeds are well damped by the bearing system. Nevertheless, the third bending mode mainly resulting from the rotor geometry and material can not be damped by the bearing system and the rotor is therefore designed such that the rated speed of 500 000 rpm is in between the second and third critical speeds. The bending modes of the turbocompressor rotor can be seen in Fig. 13.

VII. MEGANDRIVE PROTOTYPES AND MEASUREMENTS

A. 100 W, 500 000 rpm drive system

For the direct drive of miniature turbocompressors and starter/generator in gas turbines [48] a drive system with the specifications of 100 W and 500 000 rpm has been designed (Fig. 14) [34]. The operation of this drive has been experimentally verified [35]. With this system, the first application to be realized is the Solar Impulse cabin air pressurization system, shown in Fig. 12.

B. 1 kW, 500 000 rpm drive system

For a larger gas turbine, the 100 W drive system presented in Section VII.A has been adapted to operate at an increased power level of 1 kW. This leads to a machine with larger rotor diameter and length and therefore a mechanically more critical design. Furthermore, the voltage level of the power electronics is increased. This system is implemented into a mesoscale gas turbine and is used as a starter/generator. The drive system is depicted in Fig. 15.

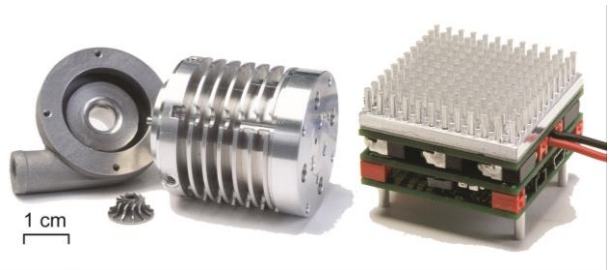

Fig. 12. Solar Impulse cabin air pressurization system.

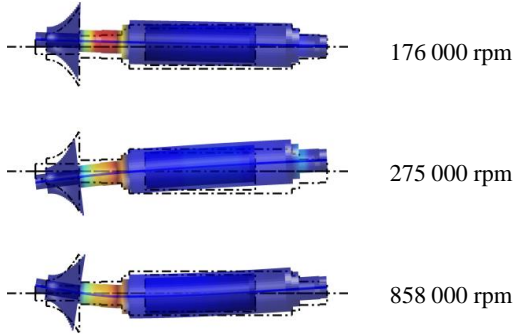

Fig. 13. Bending modes of the Solar Impulse turbocompressor rotor. The color indicates the area of highest mechanical stresses.

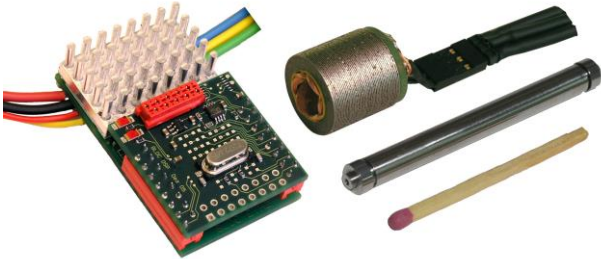

Fig. 14. 100 W, 500 000 rpm drive system including electronics, stator and test bench rotor (two magnets: motor and generator).

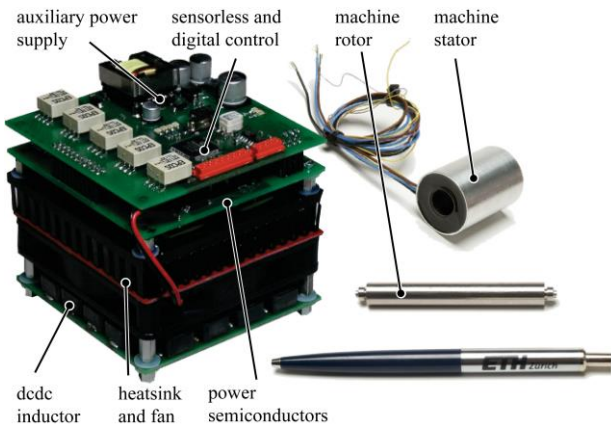

Fig. 15. Power and control electronics, stator and rotor of the 1 kW, 500 000 rpm gas turbine starter/generator.

C. 100 W, 1 000 000 rpm drive system

In order to demonstrate the feasibility of an electrical drive system with speeds beyond 1 000 000 rpm, a demonstrator system with 100 W drive power has been constructed. The machine (assembled and single rotor) is shown in Fig. 16. A high-speed, no load, which shows the targeted operation at a speed of 1 000 000 rpm test, is shown in Fig. 17. The actual maximum speed achieved with the *MegaNdrive*, before disintegration of the ball bearings, was approximately 1 100 000 rpm, although this is not documented. The terminal phase voltage, the according phase current and half bridge switching signals are measured. To ETH Zurich's knowledge, this is a world-record speed achieved by an electrical drive system.

VIII. CONCLUSION

Life sciences and nanotechnology are opening up numerous fascinating new challenges to young researchers and are giving new possibilities to discover groundbreaking knowledge. Therefore, traditional research into the already established areas in electrical engineering, besides answering industrial relevant questions, also must focus on radically new topics, which often can be found at the intersection of different technologies and/or lie in multi-disciplinary fields. In the electrical drives technology area, *MegaNdrives* represent such a field, which has a high potential to push forward new enabling technologies in a number of applications ranging from medical systems to machining technology and new portable energy generation systems. In addition, this area provides an inspiration for interdisciplinary work and has potential to substantially extend the performance space of drives and therefore could function as a lighthouse project, fascinating new generations of researchers in academia.

At ETH Zurich, we have shown in our work to date, an electrical drive system that is capable of speeds up to 1 000 000 rpm. To our knowledge this is a world record speed of an electrical drive system. To achieve these speeds, there have been significant challenges in determining the correct material selection, optimizing of the machine design and undertaking high precision manufacturing, selection of the bearing technology and analyzing the rotor dynamics. In the next step, research has begun in the area of foil, air and magnetic bearings. A



Fig. 16. Low power (100 W), ultra-high-speed (1 000 000 rpm) machine.

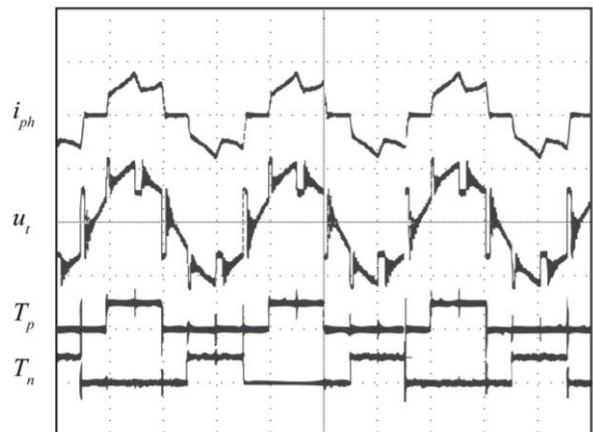

Fig. 17. Measurement (20 μ s/div) of motor phase current i_{ph} (5 A/div), terminal phase voltage u_t (25 V/div) and half bridge switching signals T_p and T_n at 1 000 000 rpm no load operation.

hybrid bearing that consists of a magnetically stabilized air bearing is a promising concept that is under consideration. Further, investigation of machines for operating at extreme ambient temperatures [49], such as in the ultracentrifuge (mega-gravity science [27]) represent a main focus of our future research. In parallel to the research left on the macro concepts, future research will focus on drive systems in the meso-scale and microsystems area. There, the power rating of today's Power MEMS, i.e. micro- to mm-scale generators and actuators need to be increased by several decades, and the rotational speeds by a further decade. This represents bright new horizons for future electric drive systems technology!

ACKNOWLEDGEMENTS

The authors would like to thank PCIM for their approval for publishing this work. Furthermore, a special thanks goes to our industrial partners, ATE Antriebstechnik und Entwicklungs GmbH, High-Speed Turbomaschinen GmbH and myonic GmbH, for providing machine prototypes and application areas.

REFERENCES

- [1] J. Szydlo, "High Speed Depth Optical Scanner", PhD Thesis, Ecole Polytechnique Federale De Lausanne, Switzerland, 2000.
- [2] A. Binder, T. Schneider, "High-Speed Inverter-Fed AC Drives," *International Aegean Conference on Electrical Machines and Power Electronics, ELECTROMOTION'07*, Bodrum, Turkey, Sept. 10-12, 2007.
- [3] A.H. Epstein, "Millimeter-Scale, MEMS Gas Turbine Engines," *Proc. of ASME Turbo Expo*, Atlanta, USA, pp. 1-28, June 2003.
- [4] S. Das, D.P. Arnold, I. Zana, J.W. Park, M.G. Allen, J.H. Lang, "Microfabricated High-Speed Axial-Flux Multiwatt Permanent-Magnet Generators – Part I: Modeling", *Jour. of Microelectromechanical Systems*, vol. 15, no. 5, pp. 1330-1350, Oct. 2006.
- [5] K. Komori and T. Yaman, "Magnetically levitated micro PM motors by two types of active magnetic bearings," *IEEE/ASME Trans. Mechatronics*, vol. 6, no. 1, pp. 43-49, 2001.
- [6] U. Kafader and J. Schulze, "Similarity relations in electromagnetic motors - limitations and consequences for the design of small dc motors," *ACTUATOR 2004, 9th International Conference on New Actuators*, Bremen, Germany, pp. 309-312, June 14-16, 2004.
- [7] I. Takahashi, T. Koganezawa, G. Su and K. Ohyama, "A Super High Speed PM Motor Drive System by a Quasi-Current Source Inverter", *IEEE Trans. Industry Applications*, vol. 30, no. 3, pp. 683-690, 1994.
- [8] <http://www.westwind-airbearings.com/specialist/waferGrinding.html>
- [9] <http://www.westwind-airbearings.com/pcb/overview.html>
- [10] M. Kauf, "Microvia Formation: Technology and Cost Comparison", URL: <http://www.circuitree.com>, Jan. 2002.
- [11] J. Thur, "Antriebssystem für höchste Geschwindigkeiten zur feldorientierten Regelung von permanenterregten Hochfrequenzspindeln ohne Drehgeber und ohne Signalrechner," PhD thesis, Bergische Universität Wuppertal, Germany, 2006.
- [12] <http://www.westwind-airbearings.com/pcb/index.html>
- [13] http://www.sirona.com/ecomaXL/index.php?site=SIRONA_COM_s_and_c_handpieces
- [14] <http://www.miti.cc/>
- [15] J.R. Bumpy, E.S. Spooner, J. Carter, H. Tennant, G. Ganio Mego, G. Dellora, W. Gstrein, H. Sutter, J. Wagner, "Electrical Machines for use in Electrically Assisted Turbochargers", in *Proc. of Power Electronics, Machines and Drives Conf.*, vol.1, no., pp. 344-349, Apr. 2004.
- [16] I. Kolmanovsky, A.G. Stefanopoulou, "Evaluation of Turbocharger Power Assist System Using Optimal Control Techniques", SAE 2000-01-0519.
- [17] F. Westin, "Simulation of turbocharged SI-engines - with focus on the turbine", PhD thesis, Royal Institute of Technology, Stockholm, Sweden, 2005.
- [18] S. Münz, M. Schier, H.P. Schmalzl, T. Bertolini, "eBooster Design and performance of a innovative electrically driven charging system, http://www.turbos.bwauto.com/files/library/bwts_library_138_325.pdf
- [19] <http://www.turbos.bwauto.com/products/eBooster.aspx>
- [20] S. Kang, S.J.J. Lee, F.B. Prinz, "Size Does Matter: The Pros and Cons of Miniaturization," *ABB Review*, 2/2002, pp. 54-62, 2002.
- [21] S.A. Jacobson and A.H. Epstein, "An Informal Survey of Power MEMS," in *Proc. of Int. Symposium on Micro-Mechanical Engineering*, pp. 1-8, Dec. 2003.
- [22] S. Kang, "Fabrication of Functional Mesoscopic Ceramic Parts for Micro Gas Turbine Engines," PhD Thesis, Stanford University, November 2001.
- [23] <http://www.m-dot.com/>
- [24] P. Tsao, M. Senesky, and S.R. Sanders, "An Integrated Flywheel Energy Storage System with Homopolar Inductor Motor/Generator and High-Frequency Drive," *IEEE Trans. on Industry Applications*, vol. 39, no. 6, pp. 1710-1725, Nov/Dec 2003.
- [25] W. Wang, "Design Of High Speed Flywheel Motor/Generator For Aerospace Applications," PhD Thesis, Pennsylvania State University, 2004.
- [26] <http://space-power.grc.nasa.gov/ppo/projects/flywheel/>
- [27] T. Mashimo, S. Okazaki and S. Shibazaki, "Ultracentrifuge apparatus to generate a strong acceleration field of over 1 000 000 g at a high temperature in condensed matter", *Rev. Sci. Instrum.*, vol. 67, no. 9, pp. 3170-3174, Sept. 1996.
- [28] J. Oyama, T. Higuchi, T. Abe, K. Shigematsu and R. Moriguchi, "The Development of Small Size Ultra-High Speed Drive System," *Power Conversion Conference - Nagoya*, pp.1571-1576, Apr. 2007.
- [29] <http://www.miti.cc/>
- [30] <http://www.calnetix.com/highspeed.cfm>
- [31] D.P. Arnold, S. Das, J.W. Park, I. Zana, J.H. Lang, M.G. Allen, "Microfabricated High-Speed Axial-Flux Multiwatt Permanent-Magnet Generators – Part II: Design, Fabrication, and Testing", *Jour. of Microelectromechanical Systems*, vol. 15, no. 5, pp. 1351-1363, Oct. 2006.
- [32] D.E. Hesmondhalgh and D. Tipping, "Design of a High-Speed Permanent Magnet Motor," *IEE Colloquium on Permanent Magnet Machines*, pp. 6/1-6/2, 15 Jun 1988.
- [33] <http://www.ate-system.de/>
- [34] C. Zwysig, J.W. Kolar, W. Thaler, M. Vohrer, "Design of a 100 W, 500000 rpm permanent-magnet generator for mesoscale gas turbines," in *IEEE Industry Applications Conference 2005*, Hong Kong, vol. 1, pp. 253-260, Oct. 2-6, 2005.
- [35] C. Zwysig, S.D. Round, and J.W. Kolar, "Analytical and experimental investigation of a low torque, ultra-high speed drive system," in *IEEE Industry Applications Conference 2006*, Tampa, FL, vol. 3, pp. 1507-1513, Oct. 8-12, 2006.
- [36] M.A. Rahman, A. Chiba, and T. Fukao, "Super high speed electrical machines – summary," in *2004 IEEE Power Engineering Society General Meeting*, Vol. 2, pp. 1272-1275, June 6-10, 2004.
- [37] P. L. Chapman and P. T. Krein, "Micromotor technology: electric drive designer's perspective," *IEEE Industry Applications Conference 2001*, Chicago, USA, vol. 3, pp. 1978-1983, Sept 30-Oct 4, 2001.
- [38] N. Bianchi, S. Bolognani, and F. Luise, "Potentials and limits of high-speed PM motors," *IEEE Trans. Industry Applications*, vol. 40, no. 6, pp. 1570-1578, Nov.-Dec. 2004.
- [39] J. Luomi, C. Zwysig, A. Looser, and J.W. Kolar, "Efficiency Optimization of a 100-W, 500 000-rpm Permanent-Magnet Machine Including Air Friction Losses," in *IEEE Industry Applications Conference 2007*, New Orleans, USA, 2007.

- [40] C. Zwyssig, S.D. Round and J.W. Kolar, "Power Electronics Interface for a 100 W, 500000 rpm Gas Turbine Portable Power Unit," *Applied Power Electronics Conference*, Dallas, Texas, USA, pp. 283-289, March 19-23, 2006.
- [41] K. H. Kim and M. J. Youn, "Performance comparison of PWM inverter and variable DC link inverter schemes for high-speed sensorless control of BLDC motor," *Electronics Letters*, Vol. 38, pp. 1294-1295, 2002.
- [42] K. Taniguchi and A. Okumura, "A PAM inverter system for vector control of induction motor," *Proc. PCC Conf.*, pp. 478-483, 1993.
- [43] J. Zhang and M. Schroff, "High-Performance Micromotor Control Systems," *The 29th Annual Conf. of the IEEE Industrial Electronics Societ, 2003.*, IECON '03, Vol. 1, 2-6, pp. 347-352, Nov. 2003.
- [44] Z.Q. Zhu, J.D. Ede and D. Howe, "Design criteria for brushless dc motors for high-speed sensorless operation," *Int. Journal of Applied Electromagnetics and Mechanics*, vol. 15 pp. 79-87, 2001/2002.
- [45] K. Iizuka, H. Uzuhashi, M. Kano, T. Endo, and K. Mohri, "Microcomputer control for sensorless brushless motor," *IEEE Trans. Ind. Applicat.*, vol. IA-21, pp. 595-601, May/June 1985.
- [46] <http://www.solarimpulse.com/>
- [47] H. Kanebako and Y. Okada, "New design of hybrid-type self-bearing motor for small, high-speed spindle," *IEEE/ASME Trans. Mechatronics*, vol. 8, no. 1, pp. 111-119, 2003.
- [48] B. Schneider, M. Bruderer, D. Dyntar, C. Zwyssig, M. Diener, K. Boulouchos, R. S. Abhari, L. Guzzella and J. W. Kolar, "Ultra-High-Energy-Density Converter for Portable Power," *Int. Workshop on Micro and Nanotechnology for Power Generation and Energy Conversion Applications*, Tokyo, Japan, pp. 81-84, Nov. 28-30, 2005.
- [49] John H. Glenn Research Center, "High-temperature Switched-Reluctance Electric Motor," <http://www.techbriefs.com/Briefs/Feb03/LEW17287.html>

BIOGRAPHIES



Christof Zwyssig (Student Member) studied electrical engineering at ETH Zurich. During his studies he dealt with power electronics, machines and magnetic bearings. At the Chalmers University of Technology in Sweden he worked with wind turbines. He received his M.Sc. degree from ETH Zurich in October 2004. Since then he has been a Ph.D. student at the Power Electronic Systems

Laboratory. His research is focused on high-speed drive systems and its power electronics.



Simon Round (SM'01) received the B.E. (Hons) and Ph.D. degrees from the University of Canterbury, Christchurch, New Zealand, in 1989 and 1993, respectively.

From 1992 to 1995 he held positions of Research Associate in the Department of Electrical Engineering at the University of Minnesota and Research Fellow at the Norwegian Institute of Technology, Trondheim, Norway. From 1995 to 2003 he was a Lecturer/Senior Lecturer in the Department of Electrical and Electronic Engineering at the University of Canterbury where he performed research on power quality compensators, electric vehicle electronics, and cryogenic power electronics. In 2001 he received a University of Canterbury Teaching Award. He has also worked as a power electronic consultant for Vectek Electronics, where he developed a "state-of-the-art" digital controller for high-power inverter systems. From 2004 to 2008 he was a Senior Researcher in the Power Electronic Systems Laboratory at ETH Zurich, Switzerland where he researched in the areas of ultra-compact power converters, applications of silicon carbide power devices, and three-phase ac-ac converters. In October 2008 he joined ABB Switzerland as the Control Platform Manager for the Power Electronics and Medium Voltage Drives Business Unit.

Dr Round has over 80 publications in journals and international conferences. He is a Senior Member of the IEEE and has been actively involved in the IEEE New Zealand South Section, where he was Vice-Chair and Chairman from 2001 to 2004.



Johann W. Kolar (SM) studied industrial electronics at the University of Technology Vienna, Austria, where he also received the Ph.D. degree (summa cum laude). From 1984 to 2001 he was with the University of Technology in Vienna, where he was teaching and working in research in close collaboration with the industry.

He has proposed numerous novel converter topologies, e.g., the VIENNA Rectifier and the Three-Phase AC-AC Sparse Matrix Converter concept. Dr. Kolar has published over 200 scientific papers in international journals and conference proceedings and has filed more than 50 patents. He was appointed Professor and Head of the Power Electronics Systems Laboratory at the Swiss Federal Institute of Technology (ETH) Zurich on Feb. 1, 2001. The focus of his current research is on ultra-compact intelligent AC-AC and DC-DC converter modules employing latest power semiconductor technology (SiC), novel concepts for cooling and active EMI filtering, multi-disciplinary simulation, bearing-less motors, power MEMS, and wireless power transmission.

Figure Captions

- Fig. 1. Emerging application areas and trends for MegaNdrives from Power MEMS and turbomachinery.
- Fig. 2. PCB spindle [12].
- Fig. 3. Electric drive dental hand piece [13].
- Fig. 4. eBooster from BorgWarner – an electrically power air compressor providing pressurized air for the support of the turbocharger at low engine speeds [19].
- Fig. 5. MIT MEMS gas turbine [3].
- Fig. 6. Stanford/M-DOT gas turbine [23].
- Fig. 7. NASA G2 flywheel for attitude control and energy storage (night-day). 40 000 rpm, 3 kW motor/generator [26].
- Fig. 8. Machine cross-section: diametrically magnetized cylindrical permanent magnet rotor inside a slotless stator.
- Fig. 9. Losses of a machine with fixed outer dimensions of the stator core ($R_5 = 8 \text{ mm}$, $L = 15 \text{ mm}$) and a shaft power of 100 W at a rotational speed of 500 000 rpm for variable magnet radius R_1 and various values of the inner radius R_4 of the stator core. The circle shows the value for the traditional design with $R_4 = 5.5 \text{ mm}$ and $R_1 = 2.5 \text{ mm}$ [34]. The loss reduction of the optimal design with $R_4 = 5.3 \text{ mm}$ and $R_1 = 1.7 \text{ mm}$ is from 14.2 W to 9 W.
- Fig. 10. Power electronics and control system for driving an ultra-high-speed permanent-magnet machine (*MegaNdrive*).
- Fig. 11. Phasor diagram for the *MegaNdrive* sensorless control (not drawn to scale).
- Fig. 12. Solar Impulse cabin air pressurization system.
- Fig. 13. Bending modes of the Solar Impulse turbocompressor rotor. Standstill (0 kHz, 0 rpm), first (2.94 kHz, 176 krpm), second (4.59 kHz, 275 krpm), and third bending mode (14.3 kHz, 858 krpm). The color shows the bending and therefore indicates the area of highest mechanical stresses.
- Fig. 14. 100 W, 500 000 rpm drive system including electronics, stator and test bench rotor (integrating two magnets for motor and generator).
- Fig. 15. Power and control electronics, stator and rotor of the 1 kW, 500 000 rpm gas turbine starter/generator.
- Fig. 16. Low power (100 W), ultra-high-speed (1 000 000 rpm) machine.
- Fig. 17. Motor phase current (5 A/div), terminal phase voltage (25 V/div) and half bridge switching signals at 1 000 000 rpm no load operation.